



YASKAWA

YASKAWA INDUSTRIAL ROBOT MOTOMAN-DA20

20 kg/ARM PAYLOAD
13-AXIS ARTICULATED

Challenging the Human Performance

The MOTOMAN-DA20 will change your image of industrial robots.
Performing tasks once done only by people opens a new realm of possibilities.

Reach high-speed motion and enhanced freedom with two 6-axis arms.

Free yourself from routine work and concentrate on more complicated tasks.

The MOTOMAN-DA20 – the new generation dual-arm robot
developed to coexist with human beings.

■ Applications

- Improved Physical Distribution
 - Classification and placement of workpieces for individual processing
 - Continuous handling with dual arms without temporary placement on table
 - Handling of heavy workpieces with dual arms
- Improved Assembly
 - Jigless assembly with dual arms
 - Complicated assembly with coordinated motion of arms
 - Coordinated labor of robots and humans with the Power Assist function

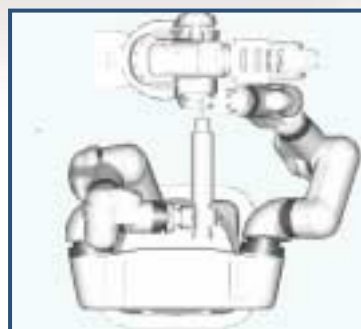

Application Examples

• Tightening bolts • Mounting parts

MOTOMAN-DA20

Manipulator Specifications

| | | | |
|----------------------|----------|--|---|
| Model | | MOTOMAN-DA20 | |
| Controlled Axis | | 13 (Articulated) [6 axes for left arm (R1), 6 axes for right arm (R2), 1 rotary axis] | |
| Payload*1 | | 20 kg/arm | |
| Repeatability*2 | | ±0.1 mm | |
| Range of Motion | Rotation | ±180° | |
| | R1 | S-axis (lifting) | +80° to -190° (R1) ; +190° to -80° (R2) |
| | | L-axis (lower arm) | +230°, -30° |
| | | U-axis (upper arm) | +215°, -35° |
| | R2 | R-axis (upper arm twist) | ±180° |
| | | B-axis (wrist pitch/yaw) | ±120° |
| T-axis (wrist twist) | | ±180° | |
| Maximum Speed | Rotation | 2.97 rad/s, 170°/s | |
| | R1 | S-axis (lifting) | 2.97 rad/s, 170°/s |
| | | L-axis (lower arm) | 2.97 rad/s, 170°/s |
| | | U-axis (upper arm) | 2.97 rad/s, 170°/s |
| | R2 | R-axis (upper arm twist) | 5.24 rad/s, 300°/s |
| | | B-axis (wrist pitch/yaw) | 5.24 rad/s, 300°/s |
| | | T-axis (wrist twist) | 10.1 rad/s, 580°/s |

| | | |
|--|--------------------------|--|
| Allowable Moment | R-axis (upper arm twist) | 58.8 N · m |
| | B-axis (wrist pitch/yaw) | 58.8 N · m |
| | T-axis (wrist twist) | 29.4 N · m |
| Allowable Inertia (GD ² /4) | R-axis (upper arm twist) | 4 kg · m ² |
| | B-axis (wrist pitch/yaw) | 4 kg · m ² |
| | T-axis (wrist twist) | 2 kg · m ² |
| Approx. Mass | | 240 kg |
| Ambient Conditions | Temperature | 0°C to +40°C |
| | Humidity | 20 to 80%RH (non-condensing) |
| | Vibration | Less than 4.9 m/s ² |
| | Others | <ul style="list-style-type: none"> Free from corrosive gasses or liquids, or explosive gasses Clean and dry Free from excessive electrical noise (plasma) |
| Power Requirement*3 | | 4.2 kVA |

*1 : Model with payloads of 10 kg/arm is also available.

*2 : Conforms to JIS B 8432.

*3 : Varies in accordance with applications and motion patterns.

Note : SI units are used for specifications.

Dimensions Units: mm

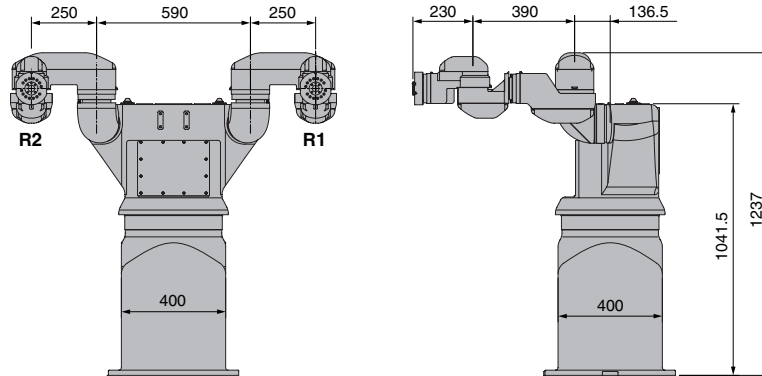

Sales Department

HEAD OFFICE

2-1 Kurosaki-Shiroishi, Yahatanishi-ku, Kitakyusyu-shi
806-0004, Japan
Phone: +81-93-645-7745 Fax: +81-93-645-7746

MOTOMAN INC. HEADQUARTERS

805 Liberty Lane, West Carrollton, OH 45449, U.S.A.
Phone: +1-937-847-6200 Fax: +1-937-847-6277

MOTOMAN ROBOTICS EUROPE AB

Franska Vagen 10, Box 4004, SE-390 04 Kalmar, Sweden
Phone: +46-480-417800 Fax: +46-480-417999

MOTOMAN ROBOTEC GmbH

Kammerfeldstrasse 1, 85391 Allershausen, Germany
Phone: +49-8166-90-0 Fax: +49-8166-90-103

YASKAWA ELECTRIC KOREA CORPORATION

1F, Samyang Bldg. 89-1, Shinchun-dong, Donk-ku, Daegu, Korea
Phone: +82-53-382-7844 Fax: +82-53-382-7845

YASKAWA ELECTRIC (SINGAPORE) PTE. LTD.

151 Lorong Chuan, #04-01, New Tech Park, Singapore 556741
Phone: +65-6282-3003 Fax: +65-6289-3003

YASKAWA ELECTRIC (MALAYSIA) SDN. BHD.

Unit 47-1&2, Jalan PJJU 5/9, Dataran Sunway, Kota Damansara, 47810,
Petaling Jaya Selangor, Malaysia
Phone: +60-3614-08919 Fax: +60-3614-08929

YASKAWA ELECTRIC (THAILAND) CO., LTD.

252/246, 4th Floor, Muang Thai-Phatra office Tower II Rachadapisek Road,
Huaykwang Bangkok, 10320, Thailand
Phone: +66-2-693-2200 Fax: +66-2-693-4200

SHOUGANG MOTOMAN ROBOT CO., LTD.

No.7 Yongchang-North Road, Beijing Economic and Technological
Development Area, Beijing 100176, China
Phone: +86-10-6788-0541 Fax: +86-10-6788-0542

MOTOMAN MOTHERSON ROBOTICS LTD.

910, DLF Galleria, DLF City Phase IV, Gurgaon - 122002 Haryana, India
Phone: +91-124-414-8514 Fax: +91-124-414-8016



YASKAWA ELECTRIC CORPORATION

YASKAWA

In the event that the end user of this product is to be the military and said product is to be employed in any weapons systems or the manufacture thereof, the export will fall under the relevant regulations as stipulated in the Foreign Exchange and Foreign Trade Regulations. Therefore, be sure to follow all procedures and submit all relevant documentation according to any and all rules, regulations and laws that may apply.

LITERATURE NO. CHEP C940440 07A

Printed in Japan February 2007 05-11

06-10

Printed on 100% recycled paper with soybean oil ink.

Specifications are subject to change without notice for ongoing product modifications and improvements.

© 2005-2007 YASKAWA ELECTRIC CORPORATION. All rights reserved.